

# COTEK

## CX-SERIES BATTERY CHARGER



CE

## Table of Content

1. IMPORTANT SAFETY INFORMATION .....	2
2. FEATURES .....	3
3. PRODUCT DESCRIPTION .....	10
4. INSTALLING THE COTEK ADVANCED CHARGER .....	16
5. TROUBLE SHOOTING .....	17
6. WARRANTY STATEMENT .....	17

## 1. IMPORTANT SAFETY INFORMATION



**WARNING!**  
**BEFORE INSTALLING OR USING CX-SERIES BATTERY CHARGER, YOU NEED TO READ FOLLOWING SAFETY INFORMATION CAREFULLY.**

### 1-1 General Safety Precautions

- 1-1-1. For indoor use, do not expose CX-Series Battery Charger to water, mist, snow, or dust. To reduce the risk of fire, do not cover or obstruct the ventilation enclosure.
- 1-1-2. To avoid the risk of fire and electric shocks, make sure that existing wiring is in good electrical condition and not undersized.
- 1-1-3. Do not charge non-rechargeable batteries.
- 1-1-4. Disconnect the AC Grid before making or breaking the connections to the battery.
- 1-1-5. Only the AC cord with IEC socket is allowed to plug to the battery charger.
- 1-1-6. Never charge a frozen battery.
- 1-1-7. If the AC cord is damaged do not attempt to use. It must be replaced or repaired by a qualified person.
- 1-1-8. Corrosive substances may escape from the battery during charging and damage delicate surfaces. Please store and charge in a suitable area.

### 1-2 Battery Precautions

- 1-2-1. If battery acid contacts your skin or clothing, wash it out with soap and water immediately.
- 1-2-2. If battery acid contacts your eyes, wash it out with cold running water for at least 20 minutes and get medical attention immediately.
- 1-2-3. Never smoke or make a spark or flame in the vicinity of the battery or the engine.
- 1-2-4. Do not drop metals on the battery.  
The resulting sparks or short-circuits on the battery or other electrical parts may cause an explosion.
- 1-2-5. Remove personal metal items such as rings, bracelets, necklaces, and watches when operating with lead-acid batteries. It may cause short circuit and very high temperature, which can melt metal items.

## 2. Features

- Universal AC input with active PFC
- Adjustable charging voltage & time setting capability for each charging stage
- Compatible with Lead Acid, Li-ion, Gel and AGM batteries
- Support remote controller CR-1 as optional accessory.
- Voltage / temperature compensation
- 2 stage fan speed control
- Output power OK signal
- Output alarm signal
- High efficiency and high reliability
- Built-in battery rescue function
- Built-in Engine Start Battery (ESB) output function
- Protection Short Circuit / Over Voltage / Over Temperature / Brown-out Protection
- Withstand 2G vibration test

### 2-1 Battery Charging Curve

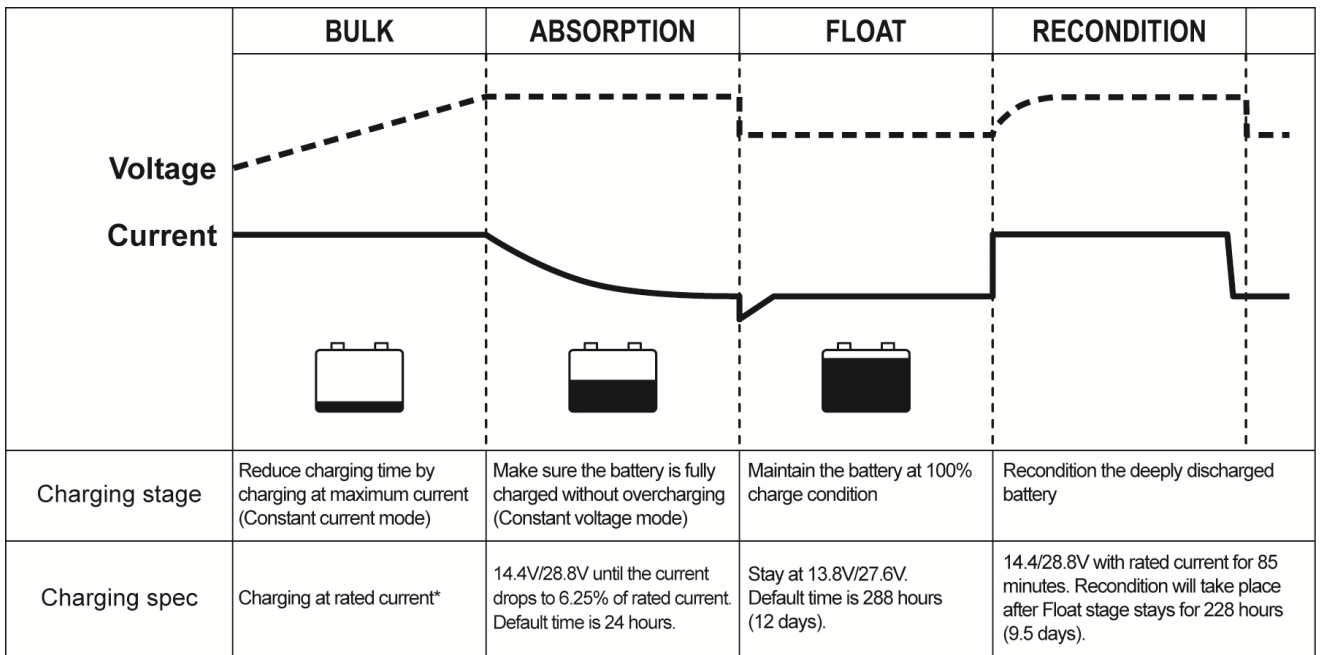

#### 2-1-1 Bulk Stage (Constant Current)

At the beginning of the charging process, the flat battery is charging at constant current (maximum charge current) until the battery voltage reaches the set charging voltage.

## **2-1-2. Absorption Stage (Constant Voltage)**

The absorption charging duration will depend on the battery status.

Before moving to absorption stage, charge will wait for two minutes then charging at constant voltage until the battery is fully charged.

Once the battery is fully charged or the charging current is below 6.25% of the rated charging current for 15 minutes, then the absorption stage ends.

## **2-1-3 Float Stage**

After absorption stage, the battery charger switches to conservation charging function, maintains the battery at 100% charge without overcharging or damaging the battery. This means the charger can be left connected to the battery indefinitely.

The battery discharges until the device re-enters the Bulk stage and charges the battery.

## **2-1-4 Re-conditioning function**

Every 12 days, the battery charger switches back to Bulk stage for 85 minutes in order to revive the battery. This prevents any fatigue symptoms such as sulphation.

## 2-2 Electrical Characteristics

### ■ CX series model

Model		CX1215	CX1225	CX1235	CX1250	CX1280	CX2415	CX2425	CX2440	
Output	Battery Type	Lead Acid / Li-ion / Gel / AGM								
	Standard Boost Charge Voltage	14.4V / 14.7V (Select by S1-1)					28.8V / 29.4V (Select by S1-1)			
	Standard Float Charge Voltage	13.8V / 13.5V (Select by S1-2)					27.6V / 27V (Select by S1-2)			
	Main Rated Current	15A	25A	35A	50A	80A	12.5A	25A	40A	
	Main Output	1	2	2	3	3	2	3	3	
	ESB Output	1	1	1	--	--	--	--	--	
	ESB Output Voltage / Current	13.8V/2A	13.8V/2A	13.8V/2A	--	--	--	--	--	
	Battery Charging Mode	3-stage charging capability IUOU								
	Isolation Type	Use active power MOSFET on each output terminal								
	Single Output Current Limit	15A	25A	35A	40A	40A	12.5A	25A	40A	
Input	Voltage Range	90~264VAC								
	Frequency Range	47~63Hz								
	Power Factor (Typ.)	PF > 0.92 at full load								
	Efficiency (Typ.) at 230Vac	87%	87%	87%	87%	87%	90%	90%	90%	
Protection	Short Circuit	Current is reduced to < 1A continued 30sec., will operate 30 seconds then turn off								
	Over Voltage	35V ±1%, Protection type: Shut down output (recovery after resetting AC power on)								
	Over Temperature	Charger Over Temperature 100 ±5°C detected by heat sink								
		52±5°C (Optional temperature sensor)								
		Auto recovery after heat sink temperature goes down to 50±5°C								
Function	Alarm Signal	NC. / NO. Relay contact output (Please reference page 5 Alarms signal & Fan control)								
	Temperature Compensation	-10mv / 0.5°C with COTEK temperature sensor								
	Charging Sleep Mode	By Remote Controller and S1-4 DIP switch (Please reference page 4~5)								
	Remote Controller	Support COTEK Remote Controller CR-1 or CR-11 setting Function (CN3 or CN4)								
Environment	Working Temp.	-20~50°C (refer to output load de-rating curve)								
	Working Humidity	20~90% RH non-condensing								
	Temp. Coefficient	±0.03% (0~50°C)								
	Vibration	10~500Hz, 2G 10min. / 1cycle period for 60min. each along X, Y, Z axes.								
Safety & EMC	Safety Standards	Certified EN 60335-1, EN60335-2-29								
	Withstand Voltage	I/P-O/P: 4242VDC, I/P-FG: 1768VDC, O/P-FG: 700VDC								
	Isolation Resistance	I/P-O/P: 100M ohms / 500VDC								
	EMI Conduction & Radiation	EN 55022; EN 55024; EN 61204-3; EN 55014-1; EN 55014-2								
	Harmonic Current	EN 61000-3-2; EN 61000-3-3; EN 61204-3; EN 61000-6-1; EN 61000-6-3								
	EMS Immunity	IEC 61000-4-2, 3, 4, 5, 6, 8, 11; ENV 50204								

Note : The specifications are subject to change without notice.

## 2-3 Mechanical Drawing

Model: CX1215/1225/1235/2415

Unit: mm

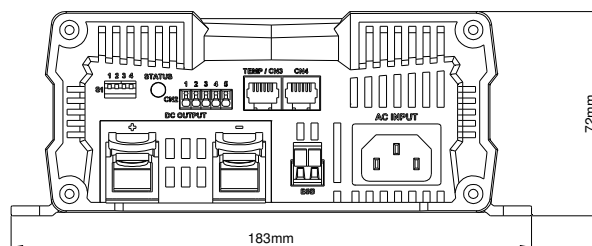
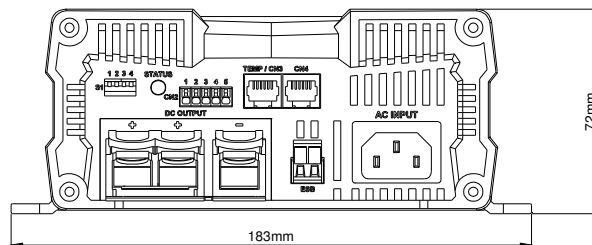
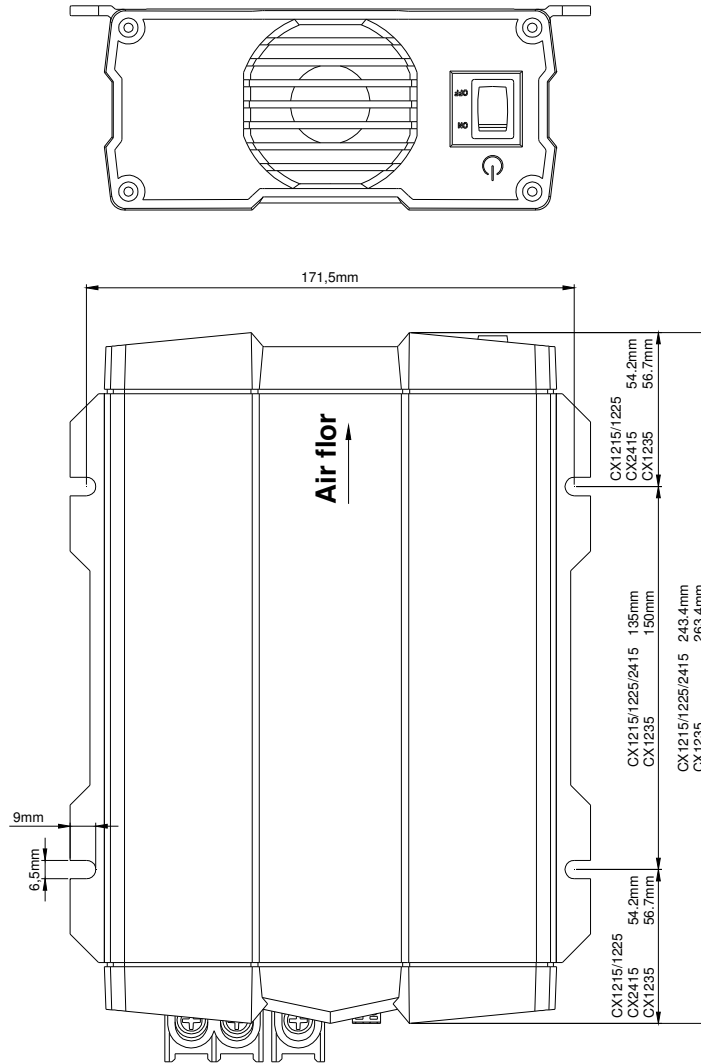

# COTEK

Model: CX1250/1280/2425/2440

Unit: mm

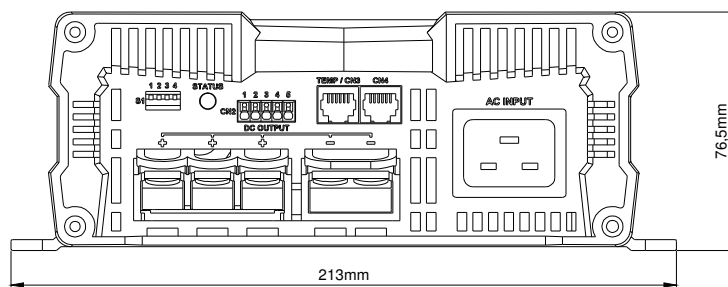
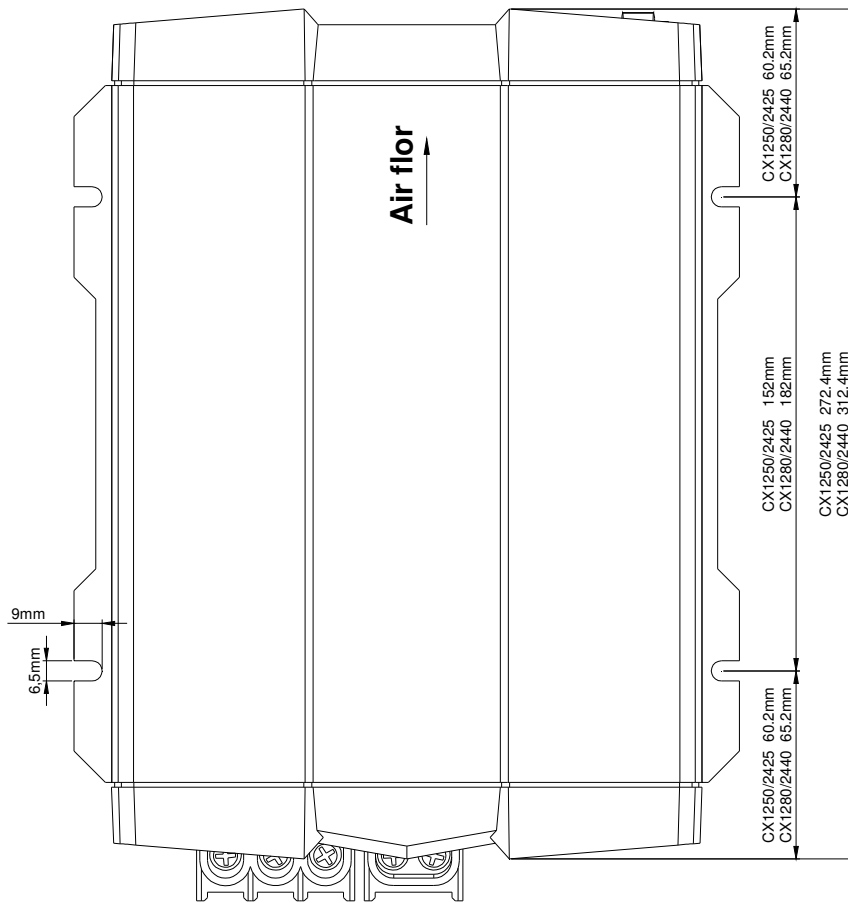
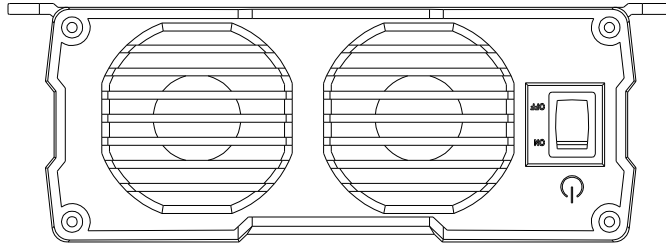



## 2-3-1 CX1215/1225/1235/2415 (Front Panel)

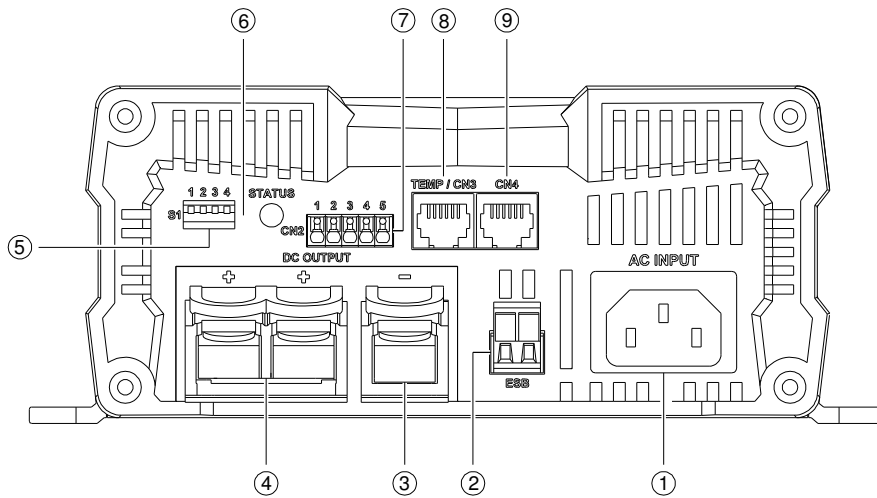

Front panel			
①	AC Inlet (IEC)	⑥	Status LED
②	ESB connector	⑦	CN2
③	DC output -	⑧	TEMP/CN3
④	DC output +	⑨	CN4
⑤	Dip Switch 1 (S1)		

*Note: Detail description on item 5 Dip Switch S1 please refer to section 3-1*

## 2-3-2 CX1215/1225/1235/2415 (Rear Panel)

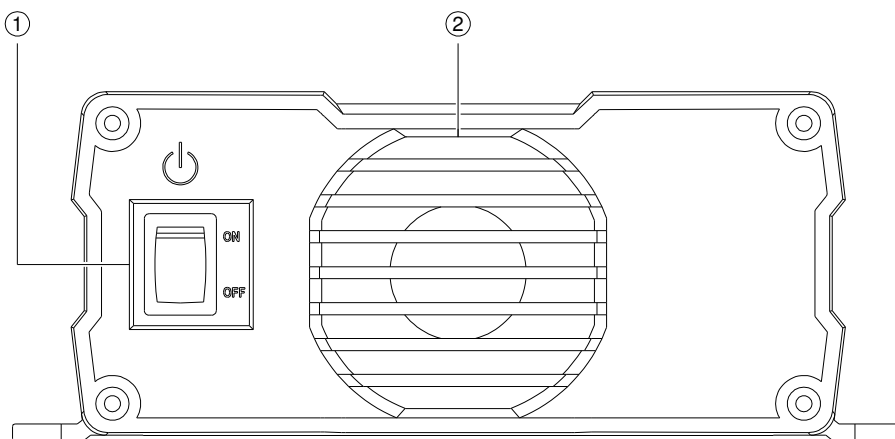

Rear panel			
①	Power Switch	②	Fan

*Note: Detail description please refer to section 3-1*

## 2-3-3 CX1250/1280/2425/2440 (Front Panel)

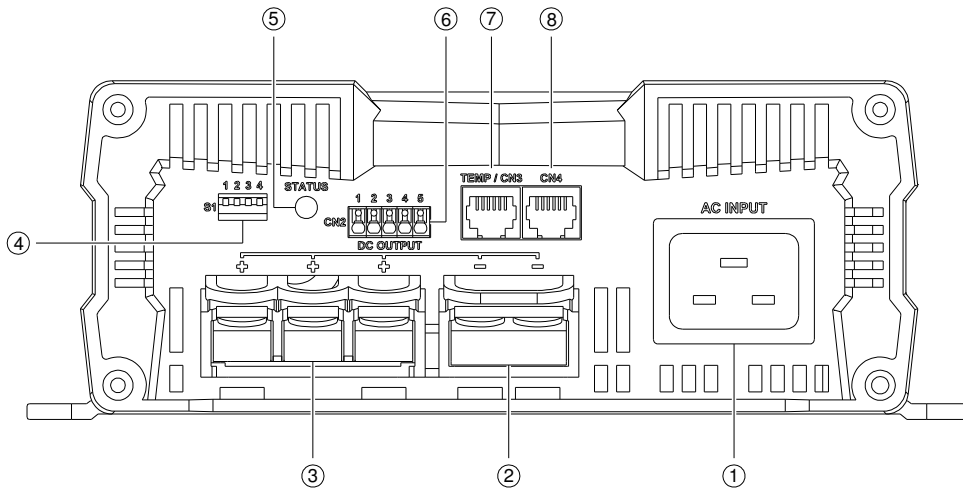

Front panel			
①	AC Inlet (IEC)	⑤	Status LED
②	DC output -	⑥	CN2
③	DC output +	⑦	TEMP/CN3
④	Dip Switch 1 (S1)	⑧	CN4

*Note: Detail description please refer to section 3-1*

## 2-3-4 CX1250/1280/2425/2440 (Rear Panel)

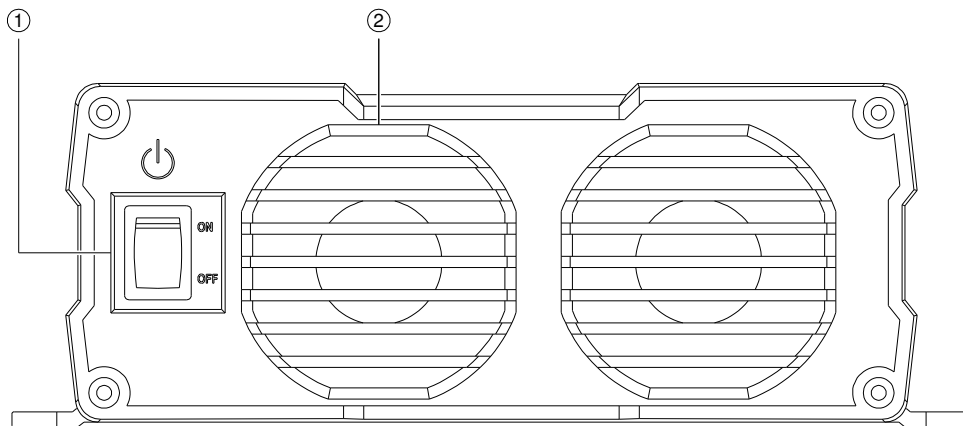

Rear panel			
①	Power Switch	②	Fan

*Note: Detail description please refer to section 3-1*





## 3. Product Description

COTEK Advanced Battery Charger CX Series has following models:

Model	No. of supply battery	Support ESB (Engine Start battery)
CX1215	1	Yes
CX1225 /CX1235	2	Yes
CX1250 /CX1280	3	No
CX2415	2	No
CX2425 /CX2440	3	No

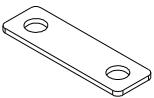
### Accessory includes:

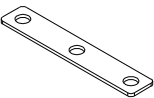
- ✓ Copper Bus x1 set
- ✓ Ring Terminal x1 set (option)
- ✓ AC Power Cable x1
- ✓ CT-20L x1 (option)
- ✓ Temp Sensor x1 (option)
- ✓ Remote CR-1 x1 (option)

Model	Diagram	Quantity	Diagram	Quantity
CX1225/1235/2415		1		2
CX1250/1280/2425/2440		1		3

### 3-1 Charging Mode Setting (S1 Dip Switch)

#### ■ CX Series model

Status	1	2	3	4	12V / 24V CC/CV	12V / 24V Float
CC turn to CV voltage	ON	X	OFF	X	14.4V / 28.8V	---
	OFF	X	OFF	X	14.7V / 29.4V	---
Float voltage	X	ON	OFF	X	---	13.5V / 27.0V
	X	OFF	OFF	X	---	13.8V / 27.6V
Power Mode (Current limit output voltage)	OFF	OFF	ON	X	13.2V / 26.4V	13.2V / 26.4V
	OFF	ON	ON	X		
	ON	OFF	ON	X		
Remote	ON	ON	ON	X	---	---
Fan force ON/OFF	X	X	X	ON	---	---
	X	X	X	OFF	---	---

### 3-1-1 Default setting

Model	12V Series	24V Series
CC/CV	14.4V	28.8V
Float	13.8V	27.6V
Power Mode	Off	Off
Remote	Off	Off
Fan	Full Speed	Full Speed

### 3-2 Charging Status And Indicator

#### ■ CX Series model

Charging status	LED Status	
Bulk-1	Orange fast	-----
Bulk-2	Orange slow	- - - - -
Absorption-1	Orange solid	=====
Absorption-2	Green solid	=====
Float	Green flash	.....
	LED color change by the status change	
Float to Bulk-1	--	

### 3-3 Failure Indicator

#### ■ CX Series model

Failure status	LED Status		Description
Input or Output	Red solid	=====	Current is reduced to <1A ,Continued 30 sec., FAN turn on 30 sec then turn off.
			AC I/P unstable
			Output FUSE blown
Temperature	Red fast	-----	Battery over heat ( the indicator available when COTEK temperature sensor connected only)
			Battery under heat ( the indicator available when COTEK temperature sensor connected only)

			Charger over heat (Heat Sink)
<b>Battery voltage</b>	Red slow	- - - - -	Battery over voltage
			Battery under voltage or output under voltage in CC mode.
<b>Fan abnormality</b>	Red light flash twice	- . . . . .	Fan abnormality
<b>ESB Failure</b>	Red light slow ones	. . . . .	ESB no output / output short

### 3-4 Temp/CN3 (Temperature sensor / Remote port)

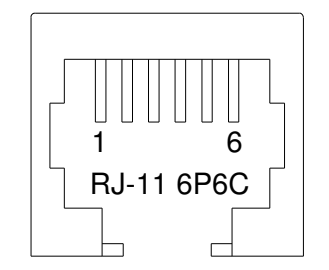
1	R_VCC	
2	GND	
3	TEMP	
4	BAT-	
5	DATA I/O	
6	BAT+	

### 3-5 CN4 (Remote port)

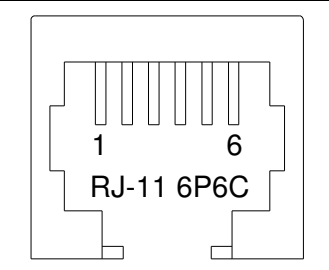
1	R_VCC	
2	BAT-	
3	NC.	
4	BAT-	
5	DATA I/O	
6	BAT+	

### 3-6 ESB Connectors only for CX1215/1225/1235

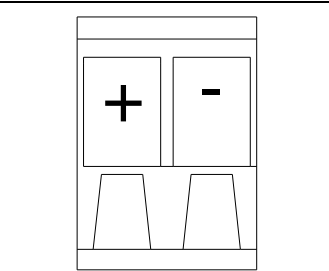
+	VCC	
-	GND	

### 3-7 Alarms Signal & Fan Control Connectors Pin Definition (CN2)

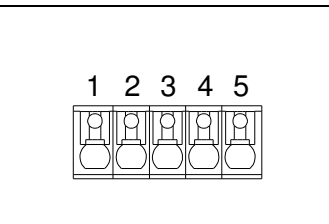
1	Normally closed	
2	Normally open	
3	COM	
4	Sleep mode control	
5	GND	

4-5 Short	Sleep mode on
4-5 Open	Sleep mode off

## 3-8 Charging Curve at Temperature Compensation

### ■ CX12xx Series model

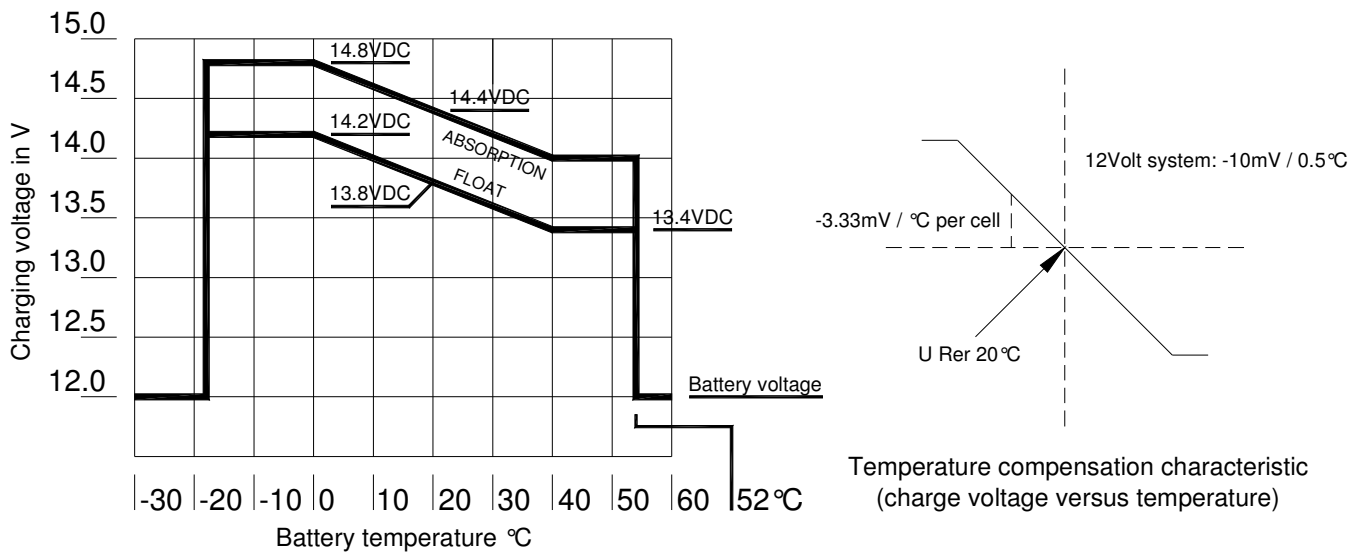

※ In the CV=14.4V and float=13.8V situation. Please follow this rule in other situation.

### ■ CX24xx Series model

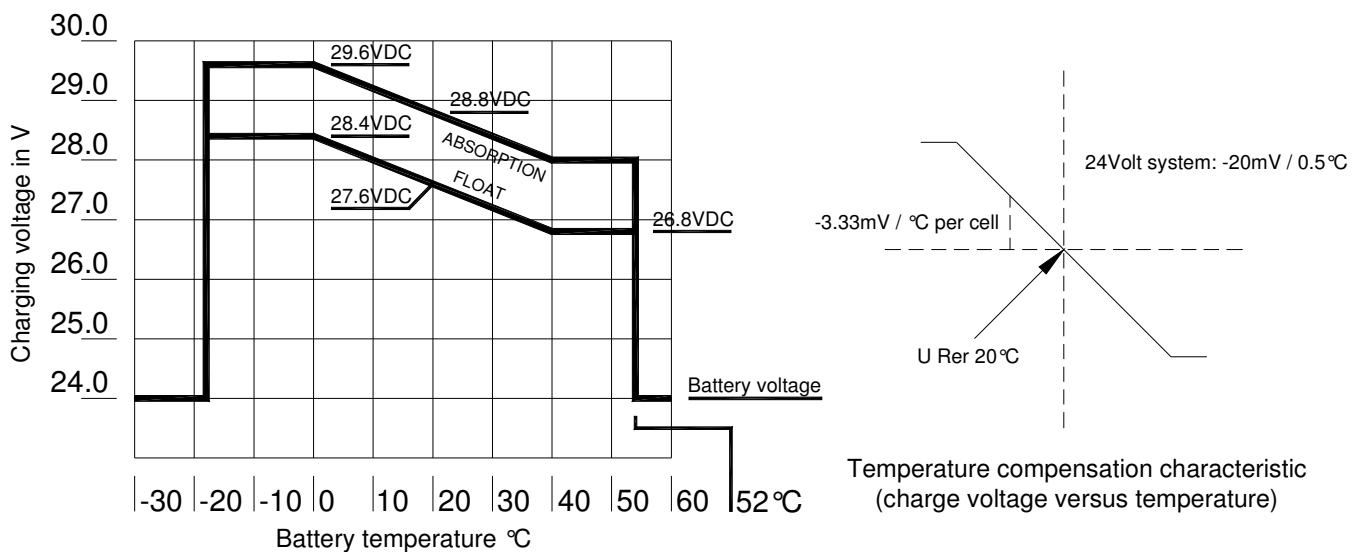

※ In the CV=28.8V and float=27.6V situation. Please follow this rule in other situation.

### 3-9 Charger Current vs Heat Sink Temperature De-rating curve.

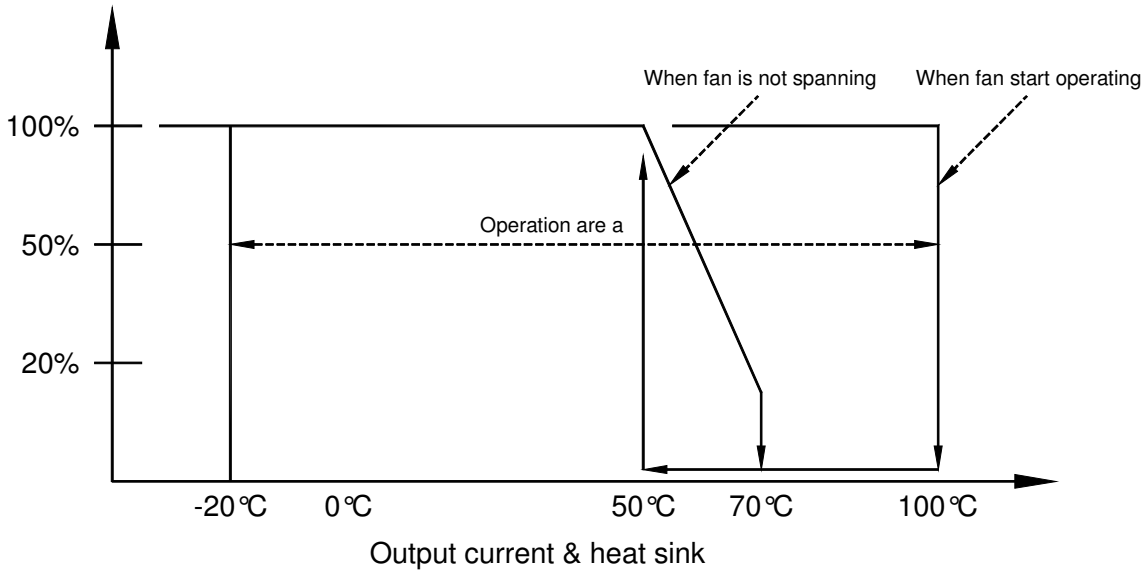

### 3-10 Rescue Battery Curve:

In case of battery over discharge (when battery voltage lower than 10V), CX battery charger will reduce the charging current to prevent further damage on the battery.

The following curve only applicable for Lead-acid & AGM battery.

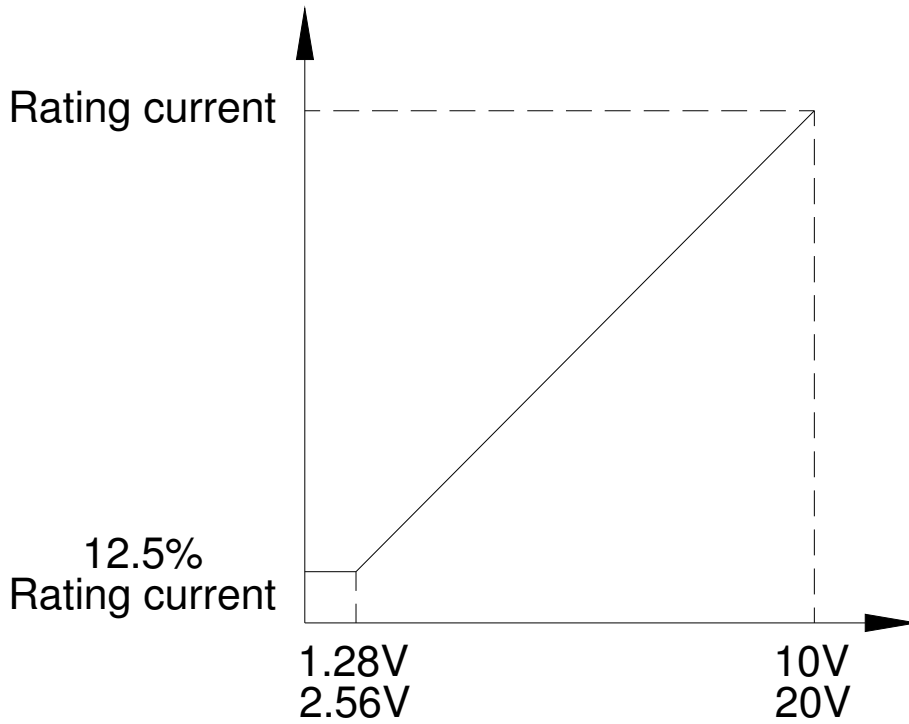

### 3-11 Battery Charger Selections (Reference only)

#### ◆ 12 Volt Batteries

COTEK Model	Battery capacity range	Estimated charging time
CX1215	50~80Ah	6~24
CX1225	80~125Ah	6~24
CX1235	125~175Ah	6~24
CX1250	175~250Ah	6~24
CX1280	250~400Ah	6~24

The above suggested battery charger selection is based on battery capacity multiply 0.2~0.3. Example: 100Ah battery \* 0.2 / 0.3 = 20A~30A in this case please select CX1225.

#### ◆ 24 Volt Batteries

COTEK Model	Battery capacity range	Estimated charging time
CX2415	50~80Ah	6~24
CX2425	80~125Ah	6~24
CX2440	125~200Ah	6~24



# COTEK

The above suggested battery charger selection is base on battery capacity multiply 0.2~0.3. Example: 100Ah battery \* 0.2 / 0.3 = 20A~30A in this case please select CX2425.

## 3-12 Battery Voltage setting suggestions

- ◆ GEL TYPE (Max. Voltage of 14.1 Volt)
- ◆ AGM TYPE (Max. Voltage of 14.4 Volt)
- ◆ Lead-Acid (Max. Voltage of 14.8 Volt)

## 4. Installing the COTEK advanced charger

When selecting the installation location, observe the following instructions:

- The battery charger can be installed horizontally or vertically.
- Do not install the charger in following situations:
  - In wet environment
  - In dusty environment
  - In the vicinity of combustible materials
  - In areas where there is a danger of explosions
- The place of installation must be well ventilated. A ventilation system must be available for installation in small, enclosed space. The clearance around the device must be at least 25cm.
- The charger must be installed on a level and sufficiently sturdy surface.
- Do not install the charger above batteries, because they can emit corrosive sulphur fumes that will damage the device.
- For ambient temperatures higher than 40 degrees (such as in engine or heating compartments, or direct sunlight), the heat from the charger under load can lead to reduced output.
- The air inlet on the underside and the air outlet on the back of charger must remain clear.

## 4-1 Battery charger connection diagram

Model: CX1215

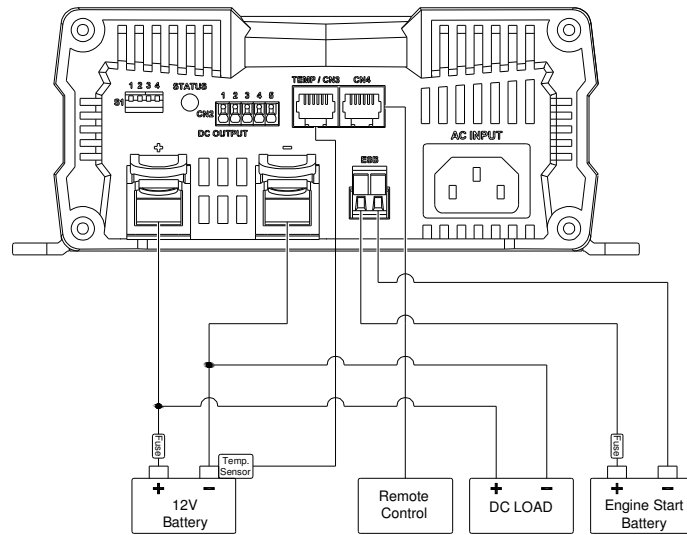

--	CX-1225	25A MAX
----	---------	---------

## Model: CX225/CX1235/2415

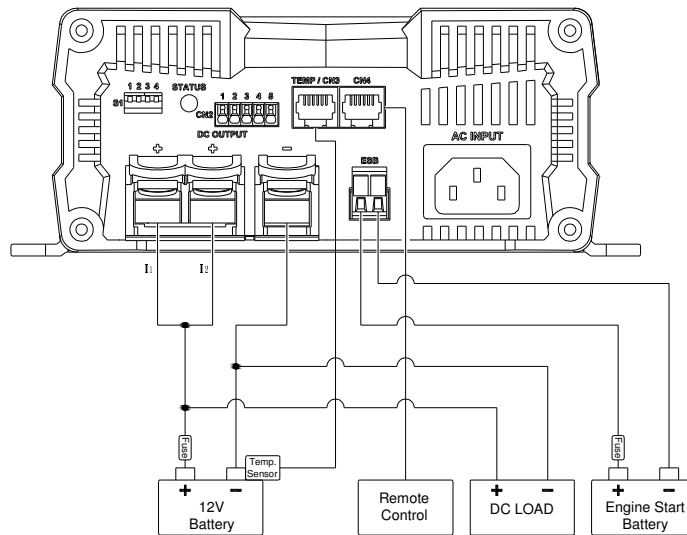

I1=I2	CX-1225	25A MAX
	CX-1235	35A MAX
	CX-2415	15A MAX

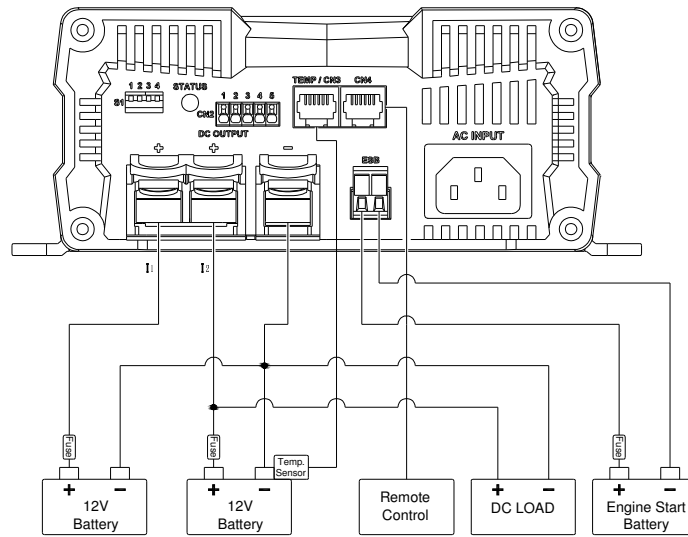

I1=I2	CX-1225	25A MAX
	CX-1235	35A MAX
	CX-2415	15A MAX

I1+I2	CX-1225	25A MAX
	CX-1235	35A MAX
	CX-2415	15A MAX

## Model: CX1250/CX1280/2425/2440

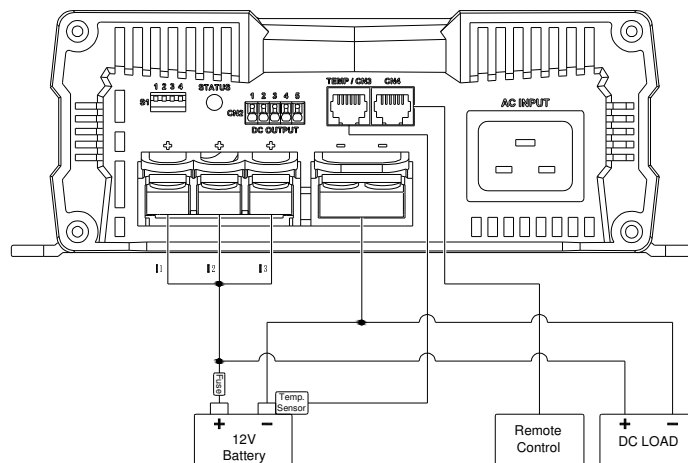

I1+I2+I3	CX-1250	50A MAX
	CX-1280	80A MAX
	CX-2425	25A MAX
	CX-2440	40A MAX

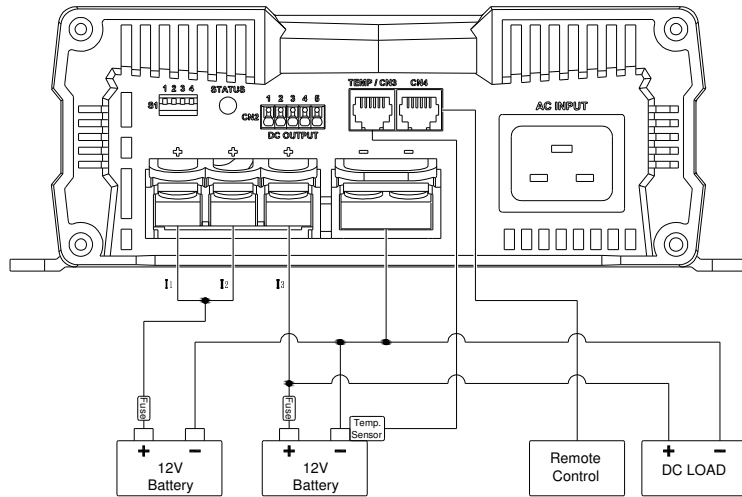

I1+I2	CX-1250	50A MAX
	CX-1280	80A MAX
	CX-2425	25A MAX
	CX-2440	40A MAX

I3	CX-1250	40A MAX
	CX-1280	40A MAX
	CX-2425	25A MAX
	CX-2440	40A MAX

I1+I2+I3	CX-1250	50A MAX
	CX-1280	80A MAX
	CX-2425	25A MAX
	CX-2440	40A MAX

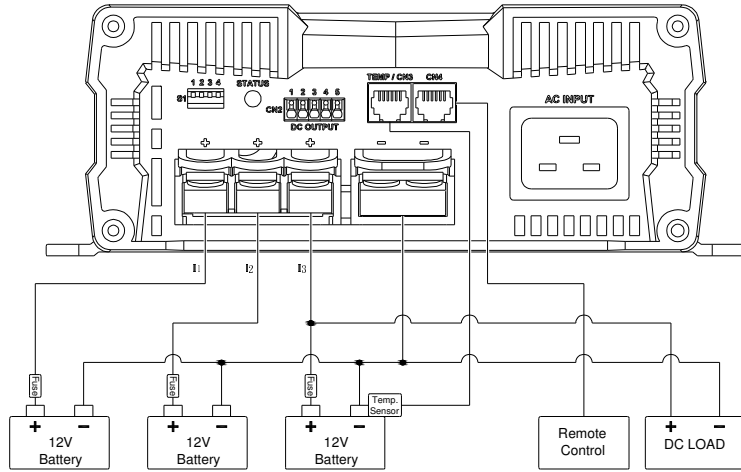

$I1=I2=I3$	CX-1250	40A MAX
	CX-1280	40A MAX
	CX-2425	25A MAX
	CX-2440	40A MAX

$I1+I2+I3$	CX-1250	50A MAX
	CX-1280	80A MAX
	CX-2425	25A MAX
	CX-2440	40A MAX

# COTEK

## 5. Trouble Shooting

LED display	Cause	Remedy
Red, slowly flashing	Battery under voltage or battery overload	Check the battery. Switch the battery charger off and on again.
	Defective battery	Replace the battery
Red, slowly flashing	Overheating	Improve the ventilation of the battery charger or battery. Make sure that no ventilation openings are covered. If necessary, reduce the ambient temperature.
Red, permanently lit	Short circuit or reversed polarity	Connect the battery charger with the correct polarity. Rectify the short circuit. Check if the fuse has blown and replace it if necessary.
Red, double flash	Fan fault	Check the fan for dirt or damage.
Red, slow double flash	Fault at the starter battery connection	Check the starter battery connection for a short circuit.

## 6. Warranty statement

COTEK ELECTRONIC IND.CO.,LTD of No.33, RONG HSIN RD., PA TEH CITY, TAOYUAN COUNTY, TAIWAN, telephone 886-3-3661581, fax 886-3-3676029, warrants that all products described in its current catalog will under normal use and service be free of failures in material and workmanship for a period of two (2) years (unless this period has been extended as indicated elsewhere) from the manufacture date of the original purchase by the customer as marked on the invoice. This warranty does not cover ordinary wear and tear, abuse, alteration of products or damage caused by the consumer.

To make a warranty claim the consumer must deliver the product at their cost to the original place of purchase or to any other place of purchase or to any other place which may be nominated by either COTEK or the retailer from where the product was bought in order that a warranty assessment may be performed. The consumer must also deliver the original invoice evidencing the date and place of purchase together with an explanation in writing as to the nature of the claim.

This warranty is in addition to any other rights or remedies that the consumer may have under Taiwan legislation.

# COTEK

## COTEK

No. 33, Rong Hsin Rd., Pa Teh City, Tao Yuan County, Taiwan

Phone : 886-3-3661581    FAX : 886-3-3676029

E-mail : [sales@cotek.com.tw](mailto:sales@cotek.com.tw)    http : // [www.cotek.com.tw](http://www.cotek.com.tw)

Update: 2013.05